

PATHWAY BARRICADES IN GROUND (PB01)

SPECIFICATIONS

STEEL TYPE:

- 47.6mm (1 7/8") O.D. PIPE

STEEL FINISH:

- POWDER COATED SAFETY
YELLOW.

- 3 STEP POWDER COAT
PROCESS:

1. SURFACE PREPARATION-
SANDBLAST METAL
2. PRIME COAT- APPLICATION OF
ZINC RICH PRIMER
3. TOP COAT- FINAL COATING IS
BAKED ON FOR THE BEST IN LONG
LASTING DURABILITY

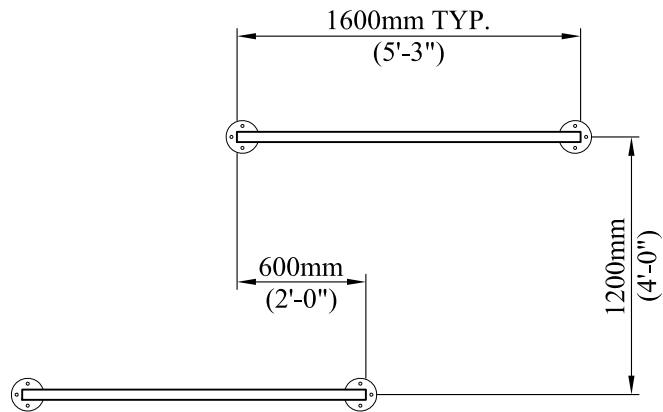

PLAN VIEW

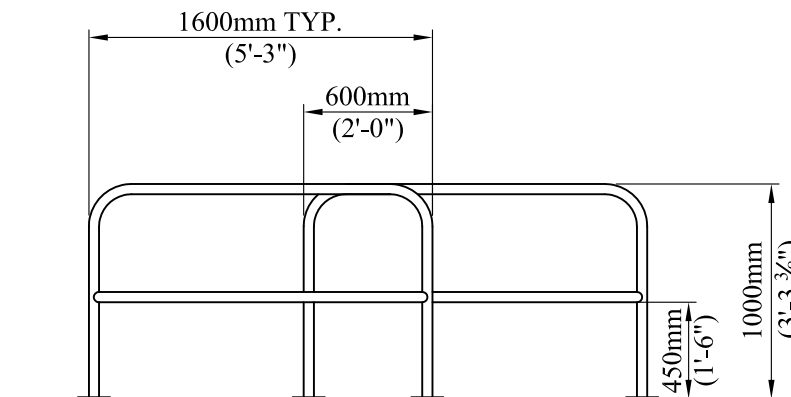

ELEVATION

SURFACE MOUNT (PB01S)

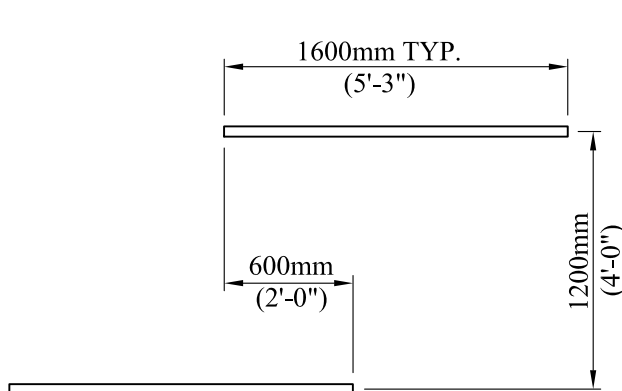

PLAN VIEW

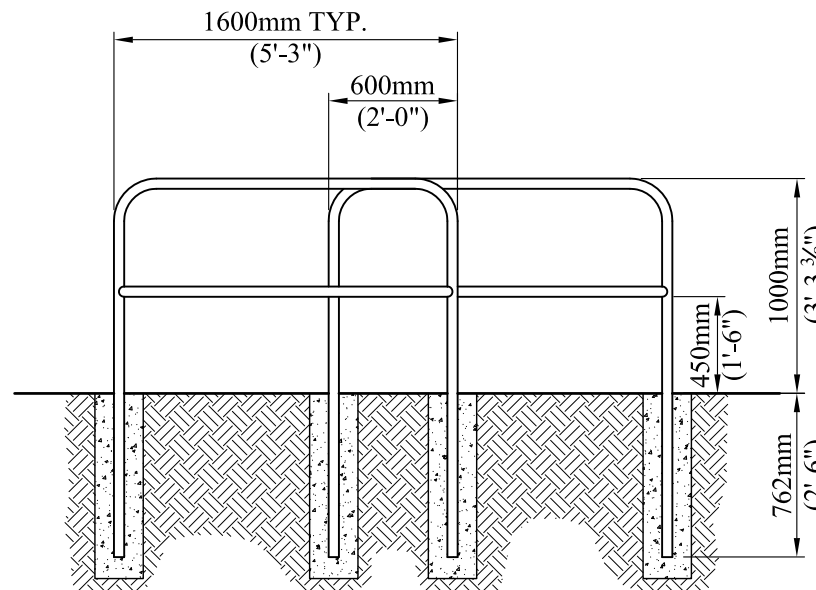

ELEVATION

IN GROUND (PB01G)

STEEL FINISH AVAILABLE IN A
WIDE VARIETY OF COLORS.
REFER TO COLOR CHART FOR
MORE INFORMATION.



4111-17th Street SE Calgary, AB T2G 3W5

Ph# 569-8180 Fax# 272-4544

e-mail: reception.cpl@telus.net

www.custompark.com