

FRONT VIEW

SURFACE MOUNT (BBS)

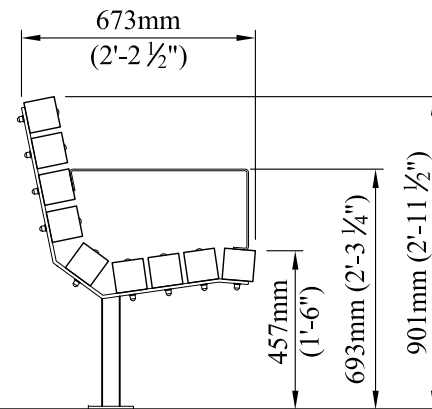

END VIEW

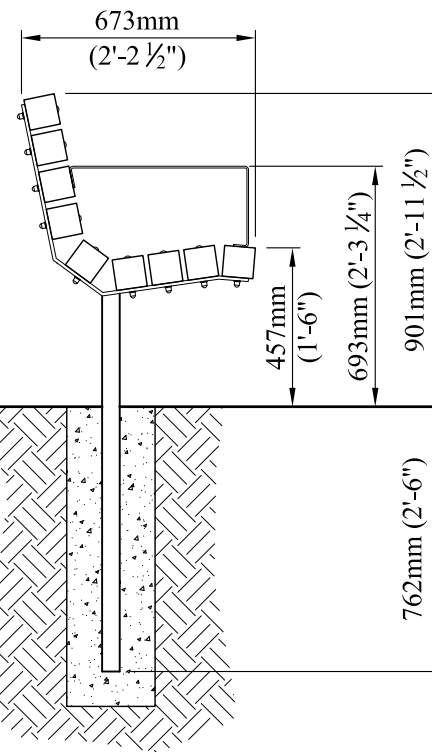

END VIEW

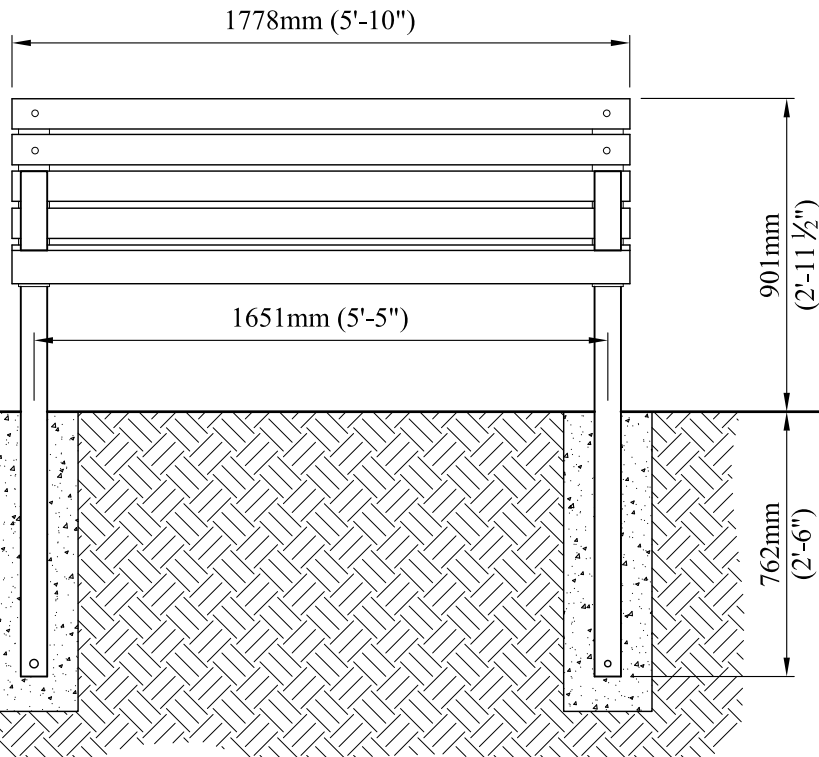

FRONT VIEW

IN GROUND (BBG)

**PARK BENCH
SERIES B**

SPECIFICATIONS

WOOD:

- 88.9 x 88.9 x 1778.0mm
(3 1/2" x 3 1/2" x 70") #1 GRADE
CLEAR CEDAR

STEEL TYPE:

- 88.9 x 9.5mm (3 1/2" x 3/8") FLAT
BAR FRAME
- 76.2 x 50.8mm (3" x 2")
RECTANGULAR TUBE LEGS
- 76.2 x 4.8mm (3" x 3/16") FLAT
BAR ARM REST

FASTENERS:

- 9.5mm (3/8") PLATED CARRIAGE
BOLTS. COLOR MATCHED TO
STEEL FRAME.

STEEL FINISH:

- 3 STEP POWDER COAT
PROCESS:
1. SURFACE PREPARATION-
SANDBLAST METAL
2. PRIME COAT- APPLICATION OF
ZINC RICH PRIMER
3. TOP COAT- FINAL COATING IS
BAKED ON FOR THE BEST IN LONG
LASTING DURABILITY

WOOD FINISH:

- AVAILABLE IN LIFETIME
PRESERVATIVE OR SIKKENS
STAIN.

STEEL FRAME AVAILABLE IN A
WIDE VARIETY OF COLORS.
REFER TO COLOR CHART FOR
MORE INFORMATION.



4111-17th Street SE Calgary, AB T2G 3W5
Ph# 569-8180 Fax# 272-4544
e-mail: reception.cpl@telus.net
www.custompark.com