

# BIKE RACK SERIES A

## SPECIFICATIONS

### STEEL:

- 60.3mm (2 3/8") O.D. PIPE FRAME

### STEEL FINISH:

- 3 STEP POWDER COAT

### PROCESS:

1. SURFACE PREPARATION-  
SANDBLAST METAL
2. PRIME COAT- APPLICATION OF  
ZINC RICH PRIMER
3. TOP COAT- FINAL COATING IS  
BAKED ON FOR THE BEST IN LONG  
LASTING DURABILITY

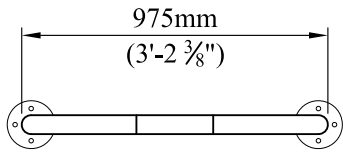

PLAN VIEW

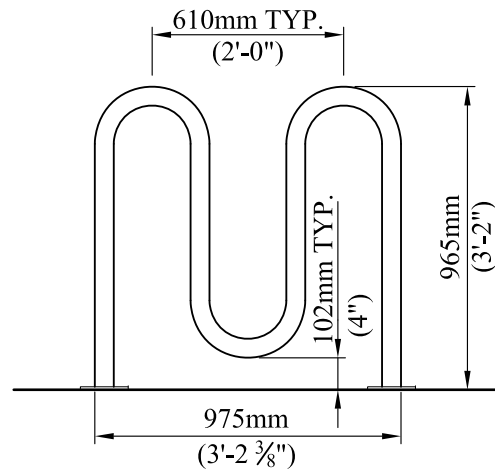

ELEVATION - 2 MOUND

SURFACE MOUNT (RAS2)

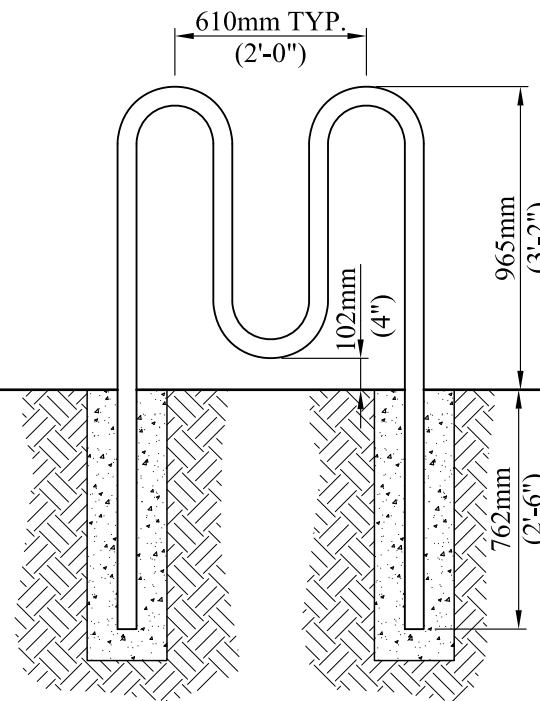

ELEVATION - 2 MOUND

IN GROUND (RAG2)

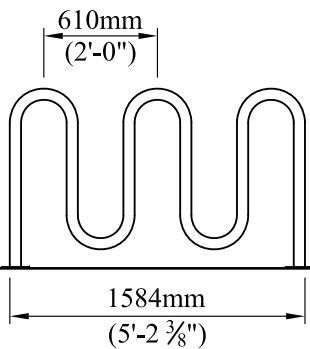

ELEVATION - 3 MOUND

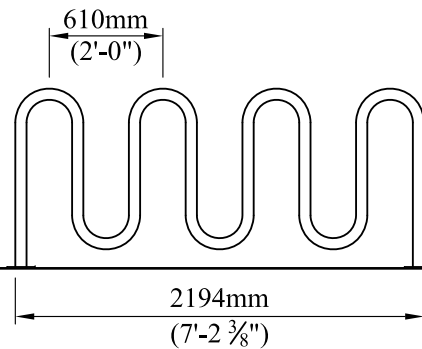

ELEVATION - 4 MOUND

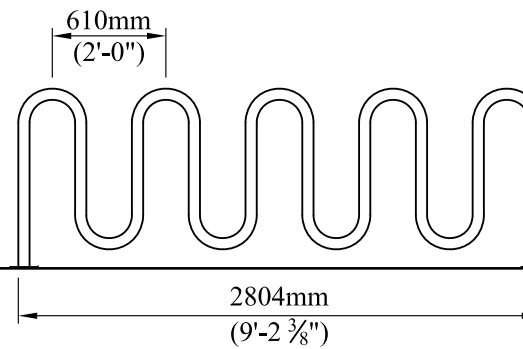

ELEVATION - 5 MOUND

STEEL FRAME AVAILABLE IN A  
WIDE VARIETY OF COLORS.  
REFER TO COLOR CHART FOR  
MORE INFORMATION.



4111-17th Street SE Calgary, AB T2G 3W5  
Ph# 569-8180 Fax# 272-4544  
e-mail: reception.cpl@telus.net  
[www.custompark.com](http://www.custompark.com)