

PICNIC TABLE - SERIES A1 IN GROUND (PA1G)

SPECIFICATIONS

WOOD:

- 38 x 139.7 x 1778.0mm
(1 1/2" x 5 1/2" x 70")

WOOD OPTIONS:

1. CEDAR- LIFETIME PRESERVATIVE OR SIKKENS STAIN.
2. PINE- ACQ PRESERVATIVE.

STEEL TYPE:

- 76.2 x 76.2mm (3"x3") ANGLE
IRON FRAME
- 76.2 x 76.2mm (3"x3") SQUARE
TUBE LEGS

FASTENERS:

- 9.5mm (3/8") PLATED CARRIAGE
BOLTS. COLOR MATCHED TO
STEEL FRAME.

STEEL FINISH:

- 3 STEP POWDER COAT
PROCESS:

1. SURFACE PREPARATION-
SANDBLAST METAL
2. PRIME COAT- APPLICATION OF
ZINC RICH PRIMER
3. TOP COAT- FINAL COATING IS
BAKED ON FOR THE BEST IN LONG
LASTING DURABILITY

STEEL FRAME AVAILABLE IN A
WIDE VARIETY OF COLORS.
REFER TO COLOR CHART FOR
MORE INFORMATION.

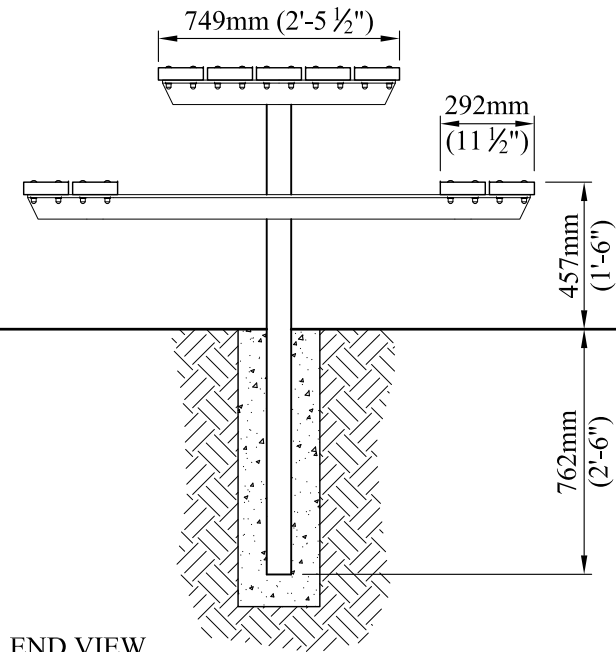

END VIEW

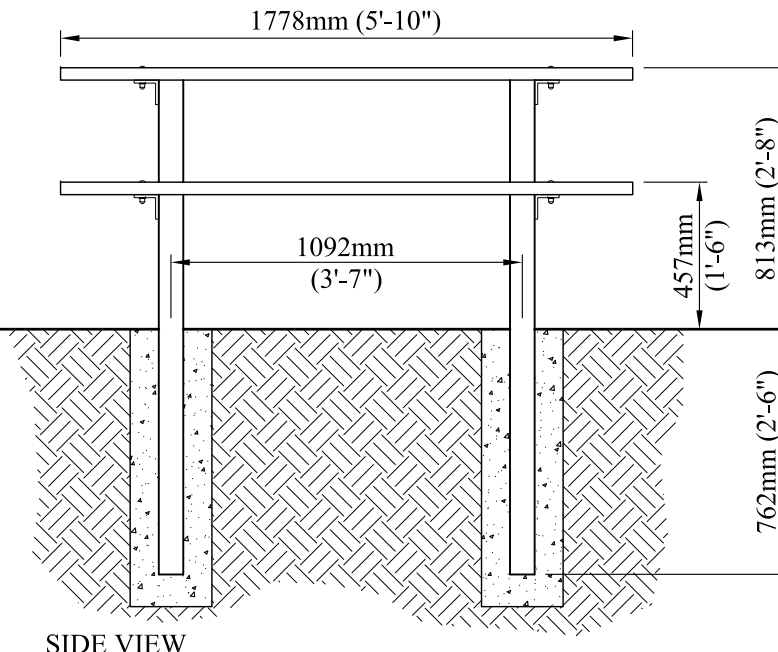

SIDE VIEW

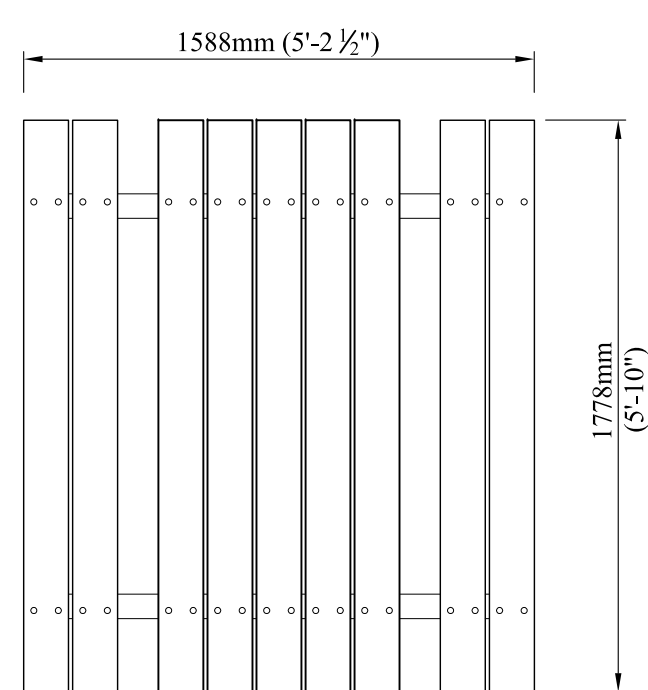

PLAN VIEW

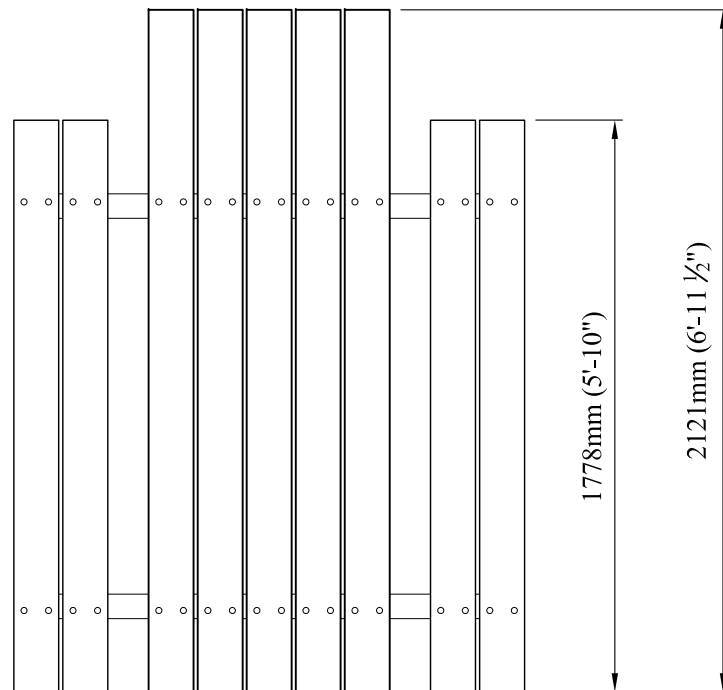

PLAN VIEW
WHEELCHAIR ACCESSIBLE



4111-17th Street SE Calgary, AB T2G 3W5
Ph# 569-8180 Fax# 272-4544
e-mail: reception.cpl@telus.net
www.custompark.com

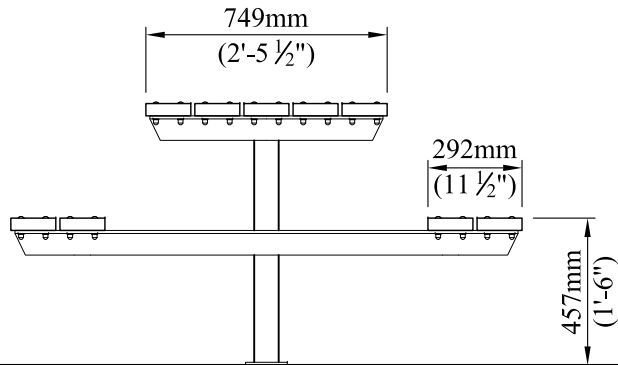

END VIEW

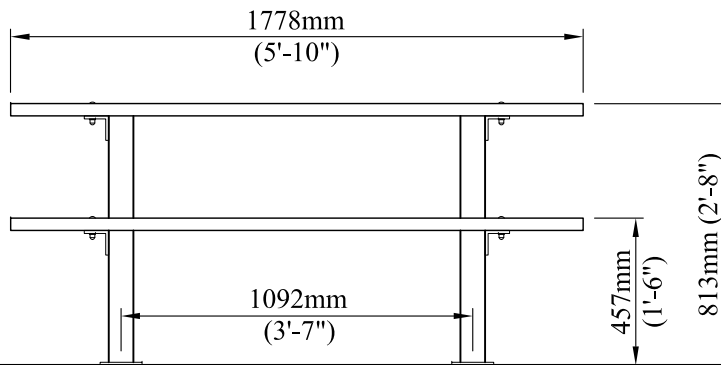

SIDE VIEW

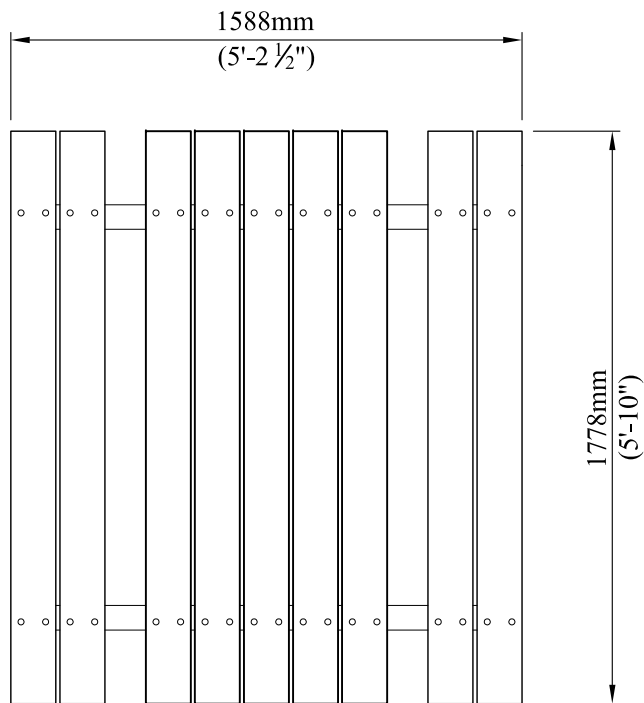

PLAN VIEW

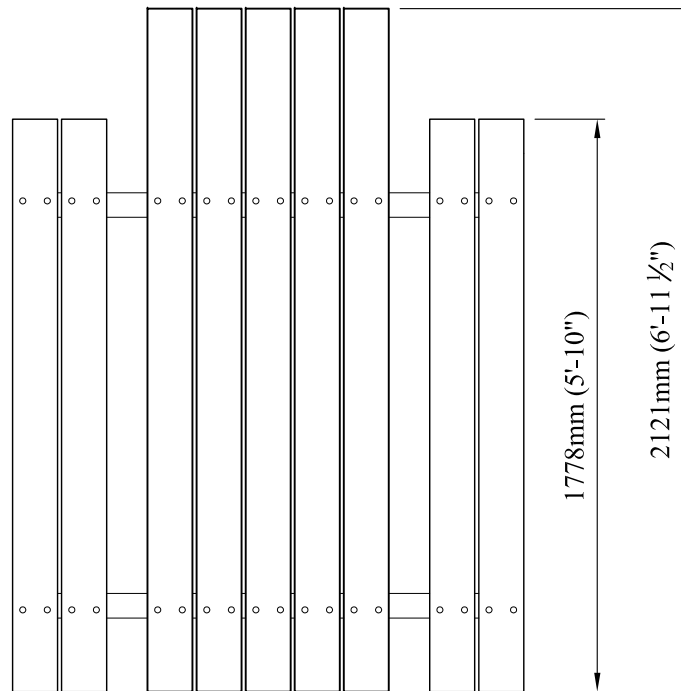

PLAN VIEW
WHEELCHAIR ACCESSIBLE

**PICNIC TABLE - SERIES A1
SURFACE MOUNT (PA1S)**

SPECIFICATIONS

WOOD:

- 38 x 139.7 x 1778.0mm
(1 1/2" x 5 1/2" x 70")

WOOD OPTIONS:

1. CEDAR- LIFETIME PRESERVATIVE OR SIKKENS STAIN.
2. PINE- ACQ PRESERVATIVE.

STEEL TYPE:

- 76.2 x 76.2mm (3"x3") ANGLE
IRON FRAME
- 76.2 x 76.2mm (3"x3") SQUARE
TUBE LEGS

FASTENERS:

- 9.5mm (3/8") PLATED CARRIAGE
BOLTS. COLOR MATCHED TO
STEEL FRAME.

STEEL FINISH:

- 3 STEP POWDER COAT
PROCESS:

1. SURFACE PREPARATION-
SANDBLAST METAL
2. PRIME COAT- APPLICATION OF
ZINC RICH PRIMER
3. TOP COAT- FINAL COATING IS
BAKED ON FOR THE BEST IN LONG
LASTING DURABILITY

STEEL FRAME AVAILABLE IN A
WIDE VARIETY OF COLORS.
REFER TO COLOR CHART FOR
MORE INFORMATION.



4111-17th Street SE Calgary, AB T2G 3W5
Ph# 569-8180 Fax# 272-4544
e-mail: reception.cpl@telus.net
www.custompark.com