

COLUMN LAYOUT

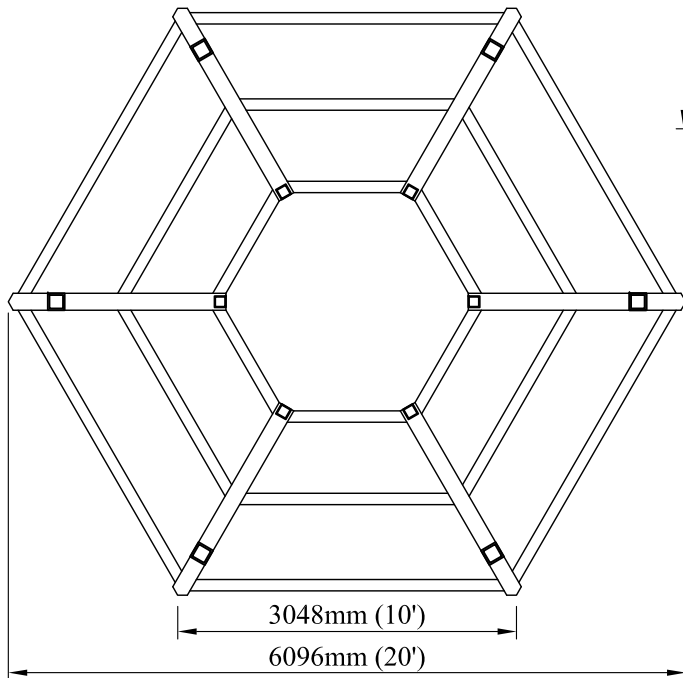

LOWER ROOF PLAN

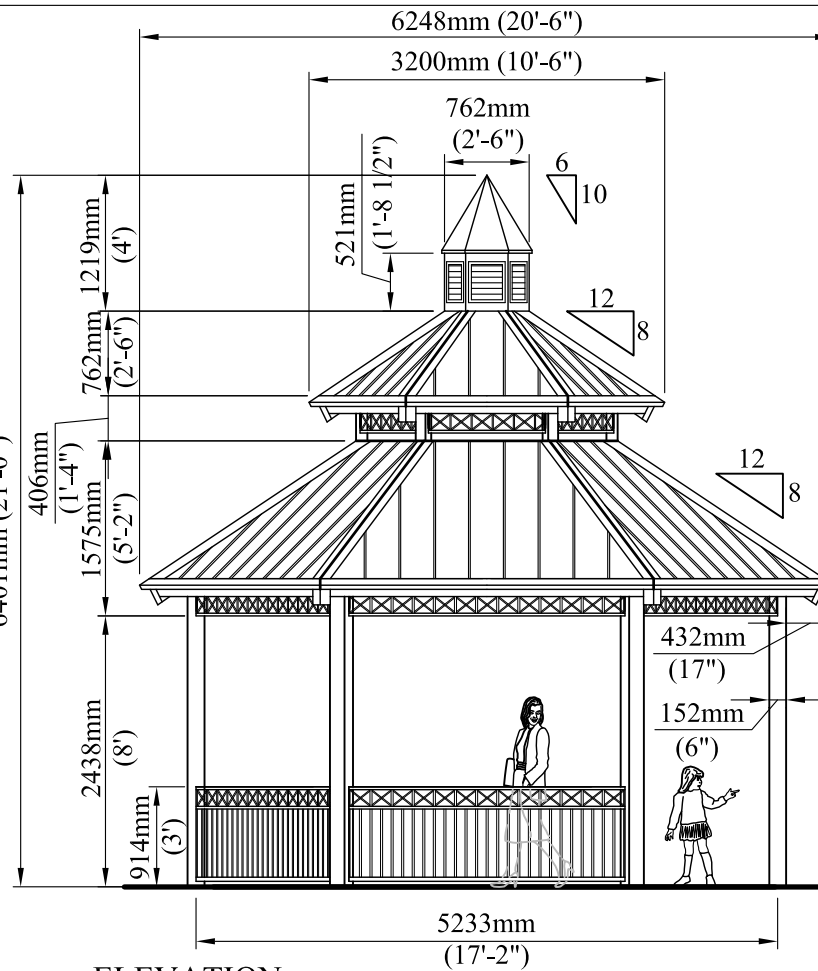

ELEVATION

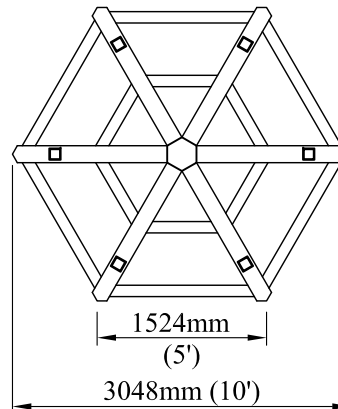

UPPER ROOF PLAN

## RIVERCREST SERIES (RIV-20) GAZEBO - 20'

### SPECIFICATIONS

#### STEEL:

- COLUMNS: 152mm x 152mm (6"x6") SQUARE TUBE.

- BEAMS: 152mm x 152mm (6"x6") SQUARE TUBE.

- RAFTERS: 101mm x 101mm (4"x4") SQUARE TUBE

- ROOF: PRE-FINISHED METAL PANEL ATTACHED DIRECTLY TO GAZEBO FRAME. OPTIONAL CEDAR SHAKES OR ASPHALT SHINGLES ARE AVAILABLE. WOOD SUBSTRUCTURE IS REQUIRED FOR THESE TWO OPTIONS.

#### STEEL FINISH:

- 3 STEP POWDER COAT PROCESS:

1. SURFACE PREPARATION- SANDBLAST METAL
2. PRIME COAT- APPLICATION OF ZINC RICH PRIMER
3. TOP COAT- FINAL COATING IS BAKED ON FOR THE BEST IN LONG LASTING DURABILITY

AVAILABLE IN A WIDE VARIETY OF COLORS. REFER TO COLOR CHART FOR MORE INFORMATION.

GENERAL CONCEPT ONLY.  
NOT FOR CONSTRUCTION.



4111-17th Street SE Calgary, AB T2G 3W5

Ph# 569-8180 Fax# 272-4544

e-mail: reception.cpl@telus.net

www.custompark.com

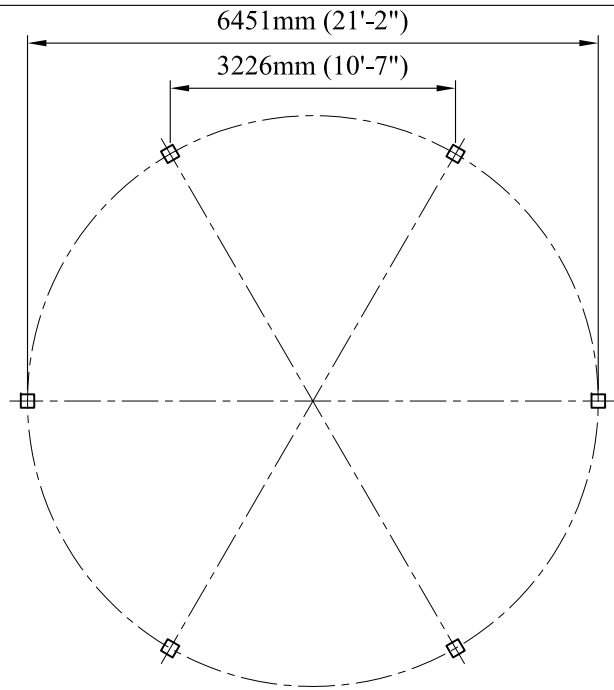

COLUMN LAYOUT

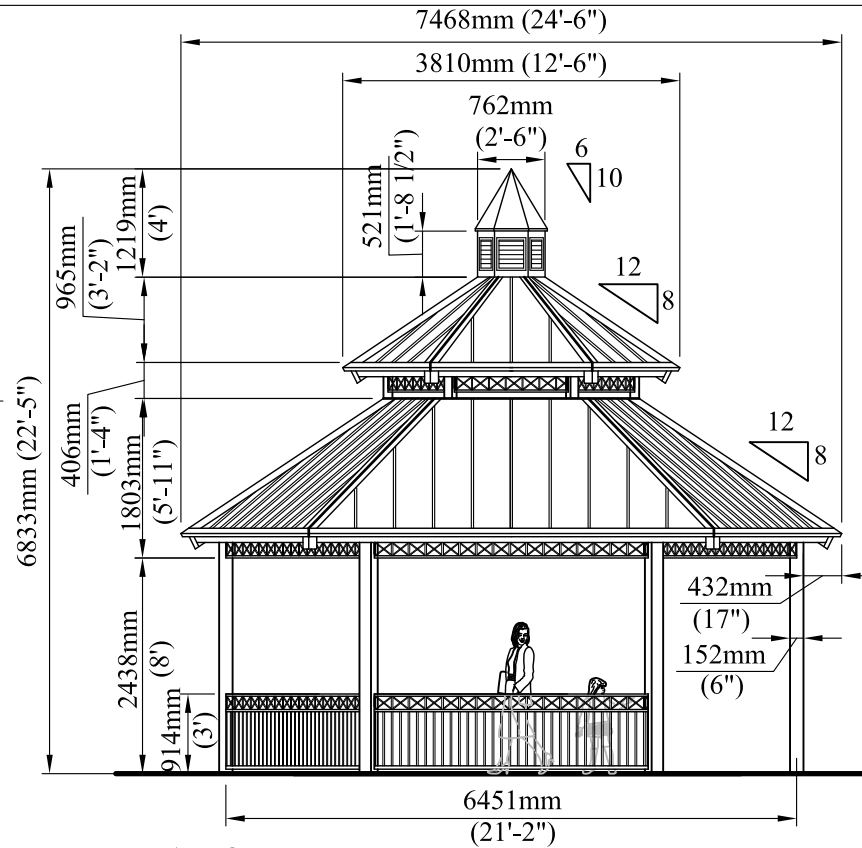

ELEVATION

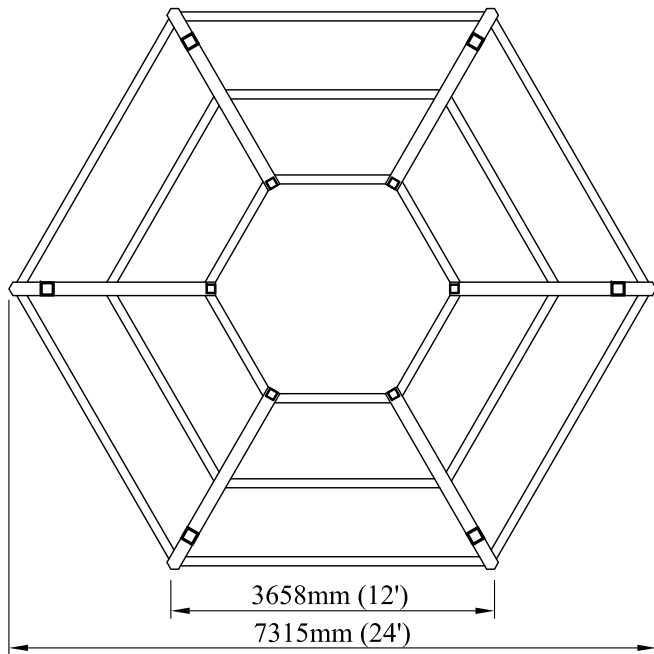

LOWER ROOF PLAN

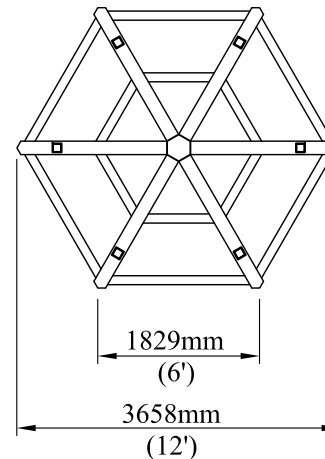

UPPER ROOF PLAN

## RIVERCREST SERIES (RIV-24) GAZEBO - 24'

### SPECIFICATIONS

#### STEEL:

- COLUMNS: 152mm x 152mm (6"x6") SQUARE TUBE.

- BEAMS: 152mm x 152mm (6"x6") SQUARE TUBE.

- RAFTERS: 101mm x 101mm (4"x4") SQUARE TUBE

- ROOF: PRE-FINISHED METAL PANEL ATTACHED DIRECTLY TO GAZEBO FRAME. OPTIONAL CEDAR SHAKES OR ASPHALT SHINGLES ARE AVAILABLE. WOOD SUBSTRUCTURE IS REQUIRED FOR THESE TWO OPTIONS.

#### STEEL FINISH:

- 3 STEP POWDER COAT PROCESS:

1. SURFACE PREPARATION- SANDBLAST METAL
2. PRIME COAT- APPLICATION OF ZINC RICH PRIMER
3. TOP COAT- FINAL COATING IS BAKED ON FOR THE BEST IN LONG LASTING DURABILITY

AVAILABLE IN A WIDE VARIETY OF COLORS. REFER TO COLOR CHART FOR MORE INFORMATION.

GENERAL CONCEPT ONLY.  
NOT FOR CONSTRUCTION.



4111-17th Street SE Calgary, AB T2G 3W5  
Ph# 569-8180 Fax# 272-4544  
e-mail: reception.cpl@telus.net  
[www.custompark.com](http://www.custompark.com)

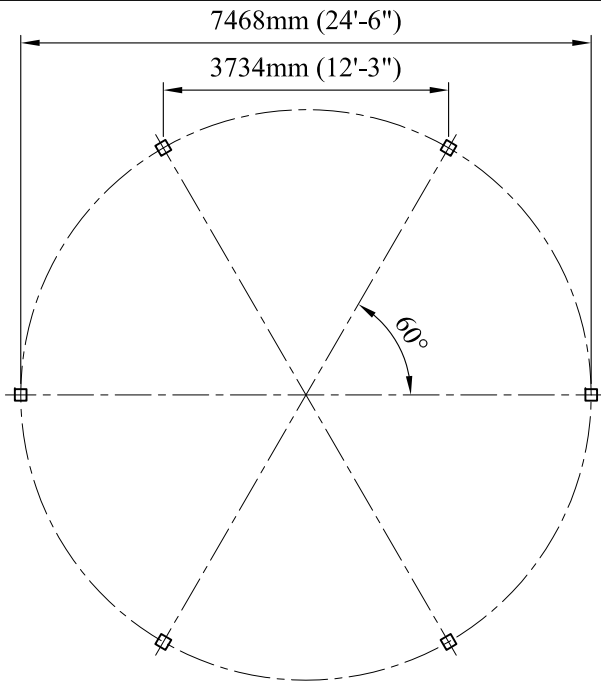

COLUMN LAYOUT

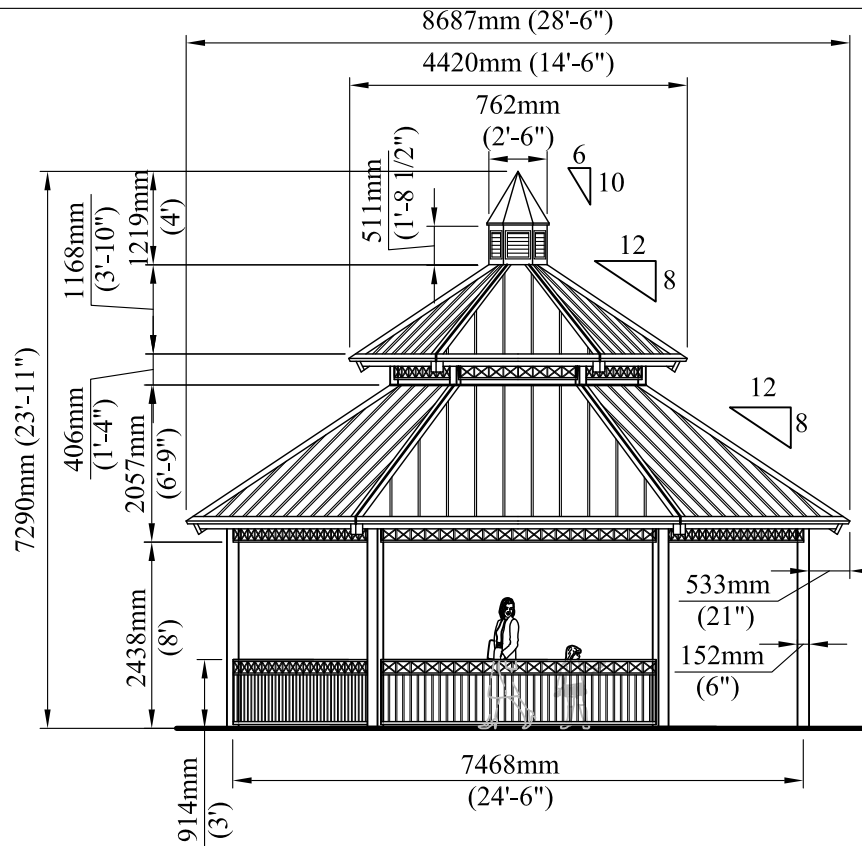

ELEVATION

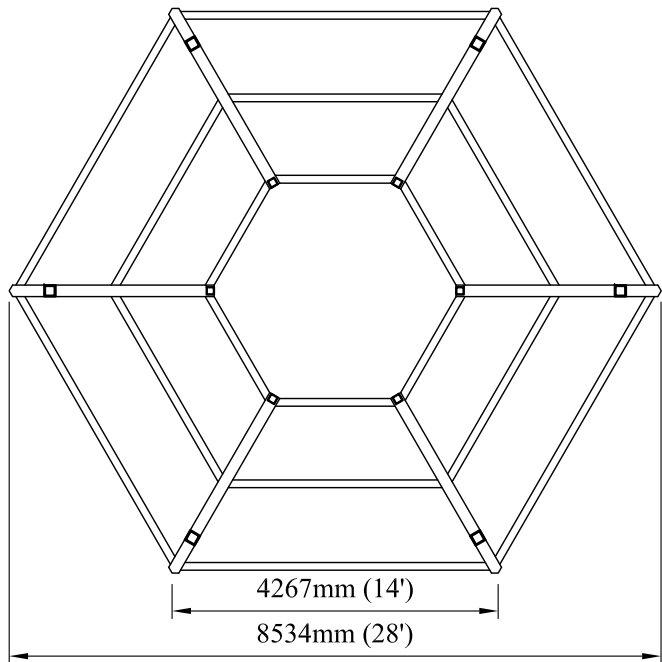

LOWER ROOF PLAN

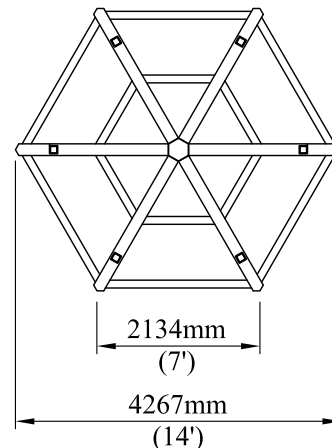

UPPER ROOF PLAN

## RIVERCREST SERIES (RIV-28) GAZEBO - 28'

### SPECIFICATIONS

#### STEEL:

- COLUMNS: 152mm x 152mm  
(6"x6") SQUARE TUBE.

- BEAMS: 152mm x 152mm (6"x6")  
SQUARE TUBE.

- RAFTERS: 101mm x 101mm  
(4"x4") SQUARE TUBE

- ROOF: PRE-FINISHED METAL  
PANEL ATTACHED DIRECTLY  
TO GAZEBO FRAME. OPTIONAL  
CEDAR SHAKES OR ASPHALT  
SHINGLES ARE AVAILABLE.  
WOOD SUBSTRUCTURE IS  
REQUIRED FOR THESE TWO  
OPTIONS.

#### STEEL FINISH:

- 3 STEP POWDER COAT  
PROCESS:

1. SURFACE PREPARATION-  
SANDBLAST METAL
2. PRIME COAT- APPLICATION OF  
ZINC RICH PRIMER
3. TOP COAT- FINAL COATING IS  
BAKED ON FOR THE BEST IN LONG  
LASTING DURABILITY

AVAILABLE IN A WIDE  
VARIETY OF COLORS. REFER  
TO COLOR CHART FOR MORE  
INFORMATION.

GENERAL CONCEPT ONLY.  
NOT FOR CONSTRUCTION.



4111-17th Street SE Calgary, AB T2G 3W5

Ph# 569-8180 Fax# 272-4544

e-mail: reception.cpl@telus.net

[www.custompark.com](http://www.custompark.com)

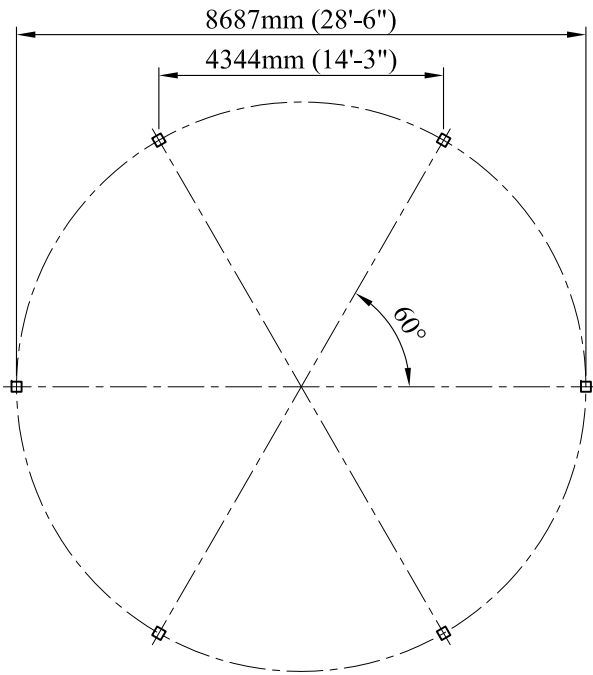

COLUMN LAYOUT

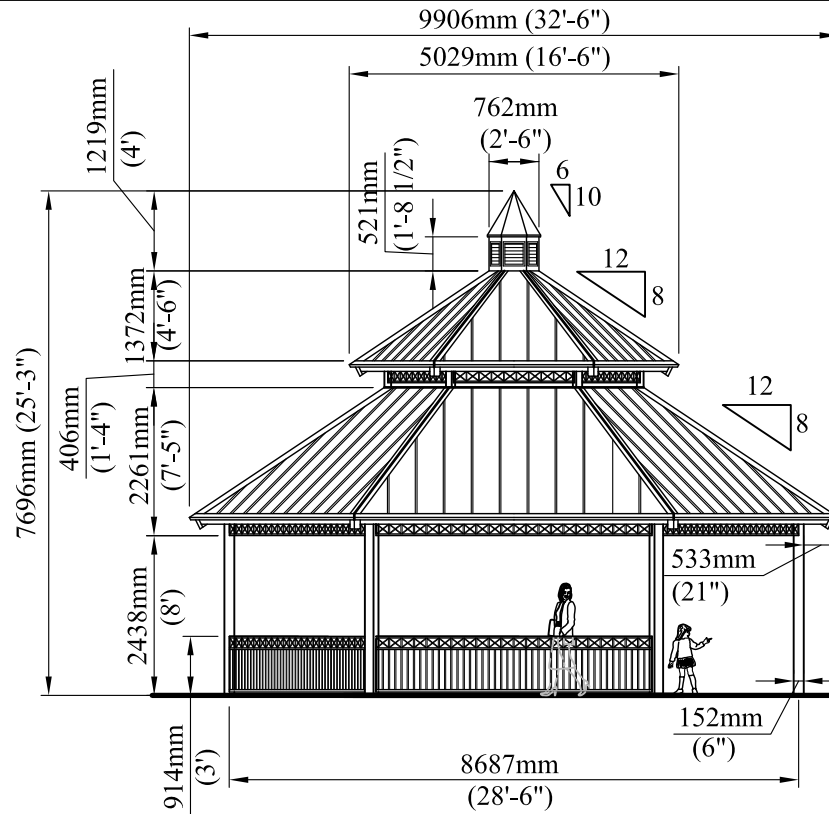

ELEVATION

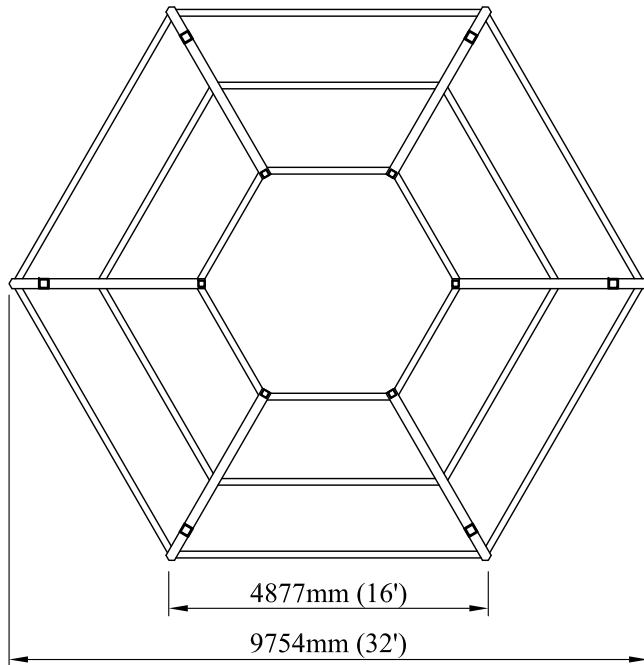

LOWER ROOF PLAN

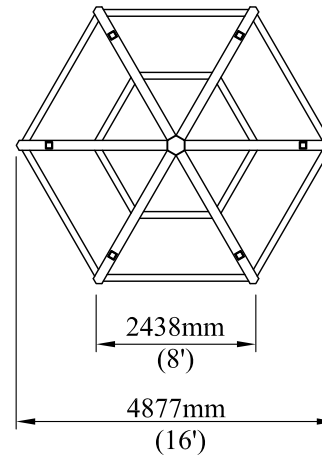

UPPER ROOF PLAN

## RIVERCREST SERIES (RIV-32) GAZEBO - 32'

### SPECIFICATIONS

#### STEEL:

- **COLUMNS:** 152mm x 152mm (6"x6") SQUARE TUBE.

- **BEAMS:** 203mm x 152mm (8"x6") SQUARE TUBE.

- **RAFTERS:** 127mm x 127mm (5"x5") SQUARE TUBE

- **ROOF:** PRE-FINISHED METAL PANEL ATTACHED DIRECTLY TO GAZEBO FRAME. OPTIONAL CEDAR SHAKES OR ASPHALT SHINGLES ARE AVAILABLE. WOOD SUBSTRUCTURE IS REQUIRED FOR THESE TWO OPTIONS.

#### STEEL FINISH:

- 3 STEP POWDER COAT PROCESS:

1. SURFACE PREPARATION- SANDBLAST METAL
2. PRIME COAT- APPLICATION OF ZINC RICH PRIMER
3. TOP COAT- FINAL COATING IS BAKED ON FOR THE BEST IN LONG LASTING DURABILITY

AVAILABLE IN A WIDE VARIETY OF COLORS. REFER TO COLOR CHART FOR MORE INFORMATION.

GENERAL CONCEPT ONLY.  
NOT FOR CONSTRUCTION.



4111-17th Street SE Calgary, AB T2G 3W5  
Ph# 569-8180 Fax# 272-4544  
e-mail: reception.cpl@telus.net  
[www.custompark.com](http://www.custompark.com)

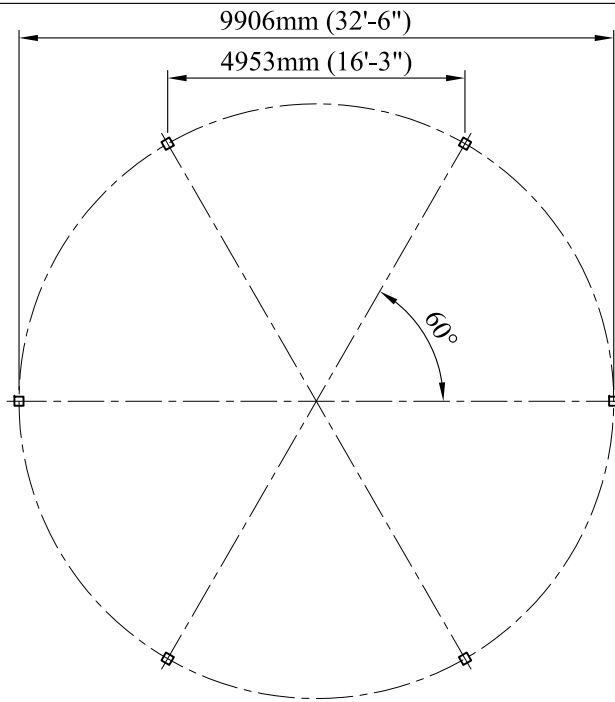

COLUMN LAYOUT

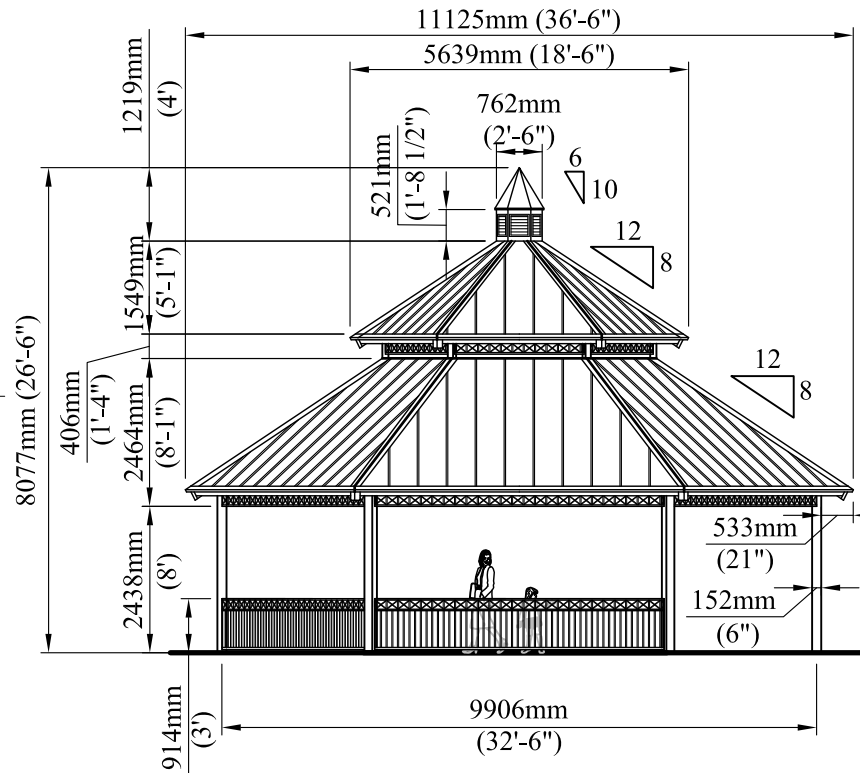

ELEVATION

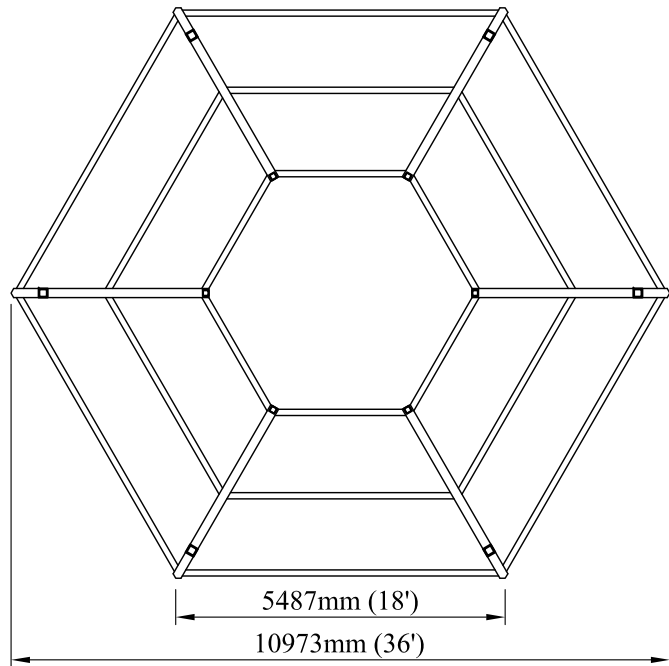

LOWER ROOF PLAN

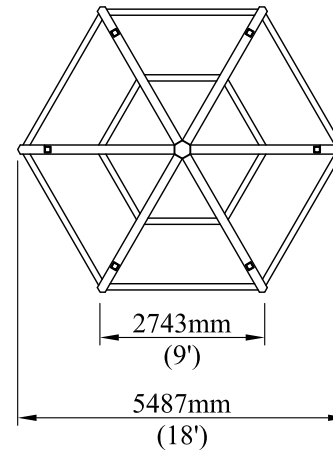

UPPER ROOF PLAN

## RIVERCREST SERIES (RIV-36) GAZEBO - 36'

### SPECIFICATIONS

#### STEEL:

- **COLUMNS:** 152mm x 152mm (6"x6") SQUARE TUBE.

- **BEAMS:** 203mm x 152mm (8"x6") SQUARE TUBE.

- **RAFTERS:** 127mm x 127mm (5"x5") SQUARE TUBE

- **ROOF:** PRE-FINISHED METAL PANEL ATTACHED DIRECTLY TO GAZEBO FRAME. OPTIONAL CEDAR SHAKES OR ASPHALT SHINGLES ARE AVAILABLE. WOOD SUBSTRUCTURE IS REQUIRED FOR THESE TWO OPTIONS.

#### STEEL FINISH:

- 3 STEP POWDER COAT PROCESS:

1. SURFACE PREPARATION- SANDBLAST METAL
2. PRIME COAT- APPLICATION OF ZINC RICH PRIMER
3. TOP COAT- FINAL COATING IS BAKED ON FOR THE BEST IN LONG LASTING DURABILITY

AVAILABLE IN A WIDE VARIETY OF COLORS. REFER TO COLOR CHART FOR MORE INFORMATION.

GENERAL CONCEPT ONLY.  
NOT FOR CONSTRUCTION.



4111-17th Street SE Calgary, AB T2G 3W5  
Ph# 569-8180 Fax# 272-4544  
e-mail: reception.cpl@telus.net  
[www.custompark.com](http://www.custompark.com)